

Christoph Färber



Progress in Detecting and Removing Cotton Contaminants in Spinning

33rd International Cotton Conference

Bremen, March 17, 2016



General Remarks

General Remarks

Cotton has been losing market share, continuously and for many years.

World Cotton Consumption and Market Share of Cotton

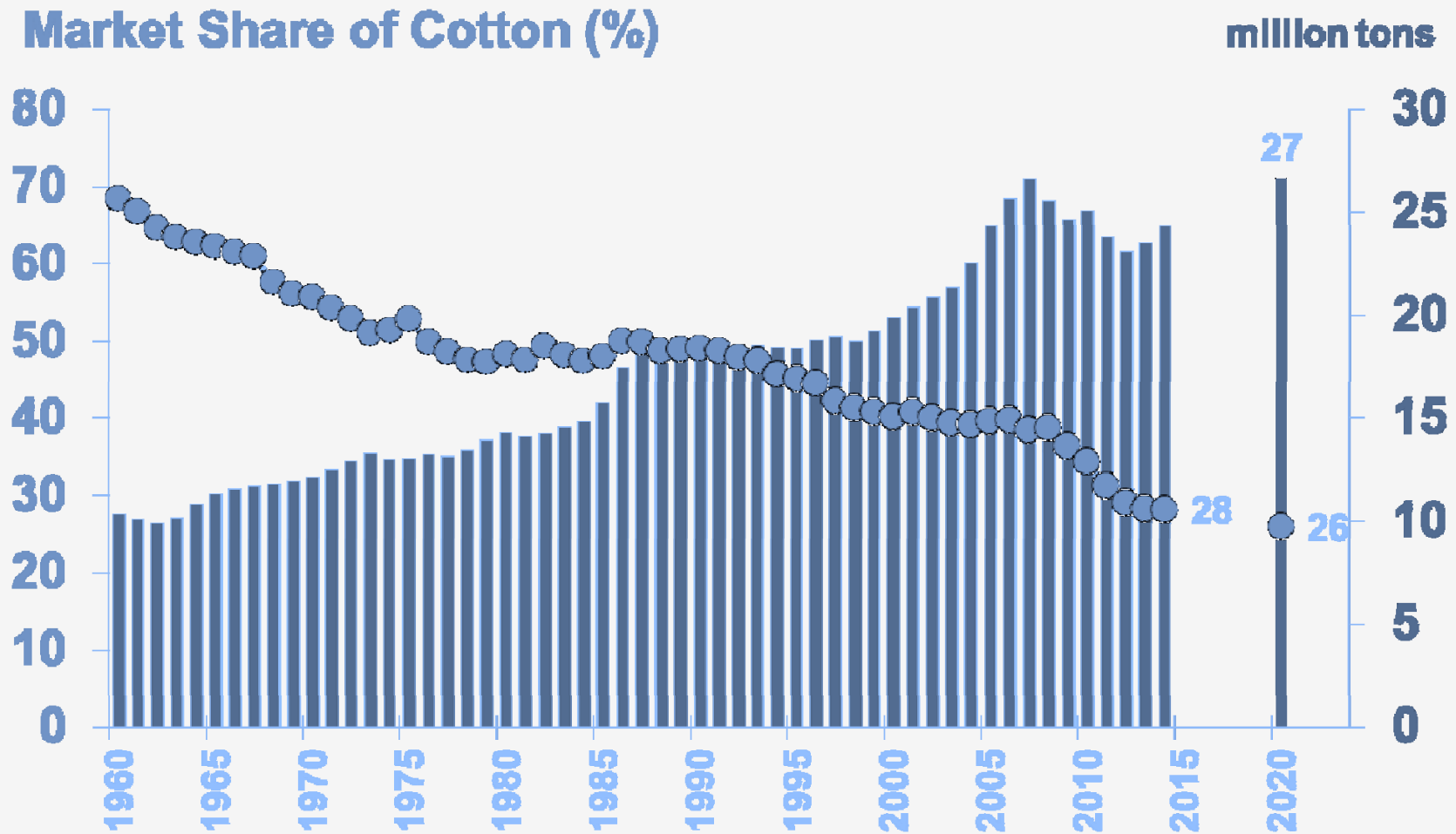

Source: ICAC

General Remarks

Cotton has been losing market share, continuously and for many years.

Cotton is substituted by Polyester as its primary competitor.

General Remarks

Cotton has been losing market share, continuously and for many years.

Cotton is substituted by Polyester as its primary competitor.

Complex global economic interactions are the reason for this trend, but there are also purely technical aspects to be considered.

	Cotton		Polyester	
Trash	1.0 ... 12.0	%	none	
Dust	200 ... 1000	g ⁻¹	none	
Short fibers by weight	6 ... 10	%	0.1 ... 0.3 %	
Fiber fragments	0.050 ... 0.400	%	none	
Neps	100 ... 350	g ⁻¹ (AFIS)	0 ... 1	g ⁻¹ (visual counting)
Seed-coat fragments	10 ... 50	g ⁻¹	none	
White specks			none	
Stickiness	0 ... 50	points	none	
Contaminants	depends on origin		none	

	Cotton		Polyester	
Trash	1.0 ... 12.0	%	none	
Dust	200 ... 1000	g ⁻¹	none	
Short fibers by weight	6 ... 10	%	0.1 ... 0.3 %	
Fiber fragments	0.050 ... 0.400	%	none	
Neps	100 ... 350	g ⁻¹ (AFIS)	0 ... 1	g ⁻¹ (visual counting)
Seed-coat fragments	10 ... 50	g ⁻¹	none	
White specks			none	
Stickiness	0 ... 50	points	none	
Contaminants	depends on origin		none	



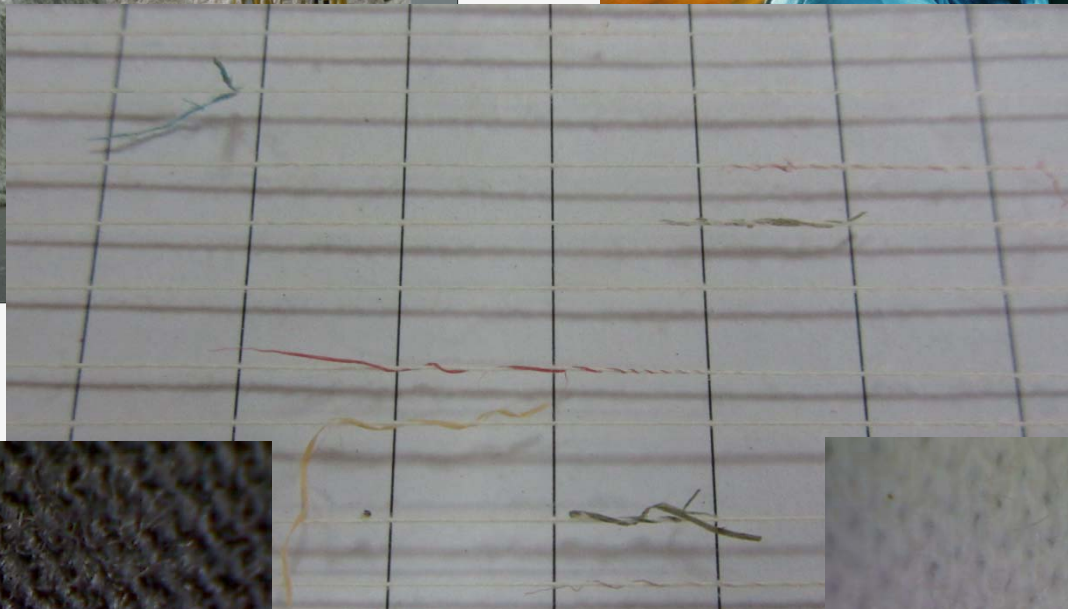

General Remarks

Cotton contamination is an issue that cotton producers are seemingly unable to resolve.

General Remarks

Cotton contamination is an issue that cotton producers are seemingly unable to resolve.

Spinners worldwide therefore took the initiative and invested some US\$ 0.5 billion in electronic systems for contaminant detection/removal in cotton cleaning lines since the mid 90's.

General Remarks

Cotton contamination is an issue that cotton producers are seemingly unable to resolve.

Spinners worldwide therefore took the initiative and invested some US\$ 0.5 billion in electronic systems for contaminant detection/removal in cotton cleaning lines since the mid 90's.

That is not counting electronic yarn clearers with foreign fiber detection capabilities installed on spinning and winding machines.

General Remarks

The total investment in all systems to prevent cotton contamination problems therefore is in the range of low single digit billions of US\$.

General Remarks

The total investment in all systems to prevent cotton contamination problems therefore is in the range of low single digit billions of US\$.

The spinners' money spent for a solution to the problem went to European machinery/electronics manufacturers.

General Remarks

The total investment in all systems to prevent cotton contamination problems therefore is in the range of low single digit billions of US\$.

The spinners' money spent for a solution to the problem went to European machinery/electronics manufacturers.

In a figurative sense: Some of that money went to people like myself and not to the cotton producers for a solution at their end.

General Remarks

Spinners are willing to and actually do pay us money to fix the problem. But, they want it fixed 100%. They constantly challenge us to develop the “perfect machine”.

General Remarks

Spinners are willing to and actually do pay us money to fix the problem. But, they want it fixed 100%. They constantly challenge us to develop the “perfect machine”.

Our response to that is the new T-SCAN or TS-T 5 foreign matter separator.

T-SCAN or TS-T 5

Electronic camera-based foreign matter separator installed in the cotton cleaning line

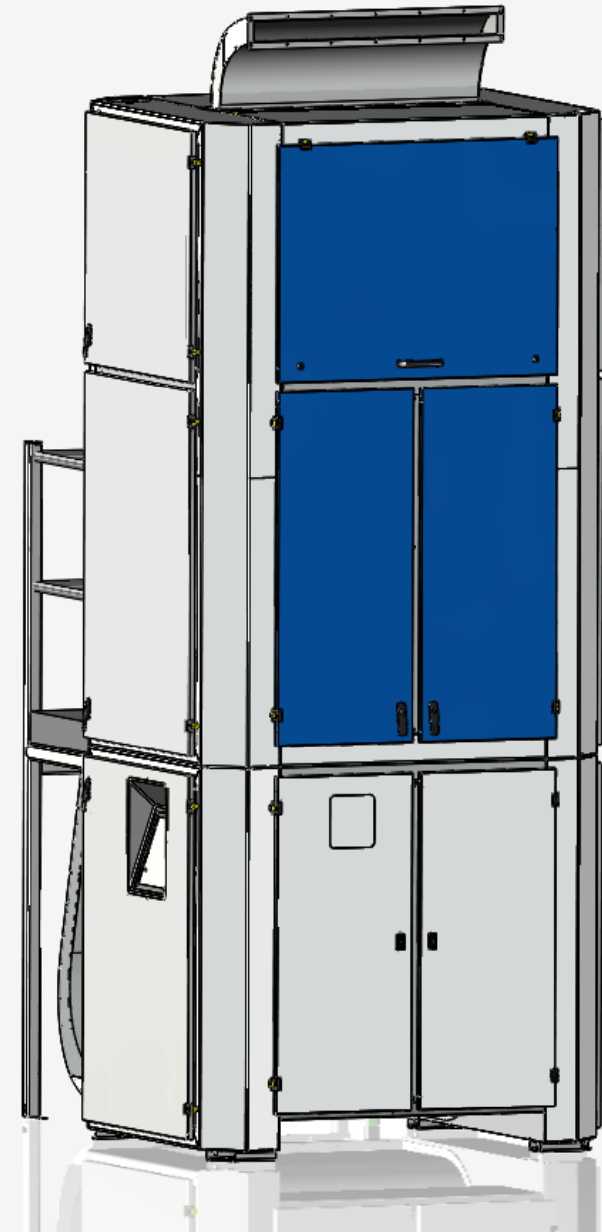

T-SCAN or TS-T 5

Electronic camera-based foreign matter separator installed in the cotton cleaning line

Scans the cotton with advanced industrial image analysis technology while tufts are passing through the machine carried by air flow

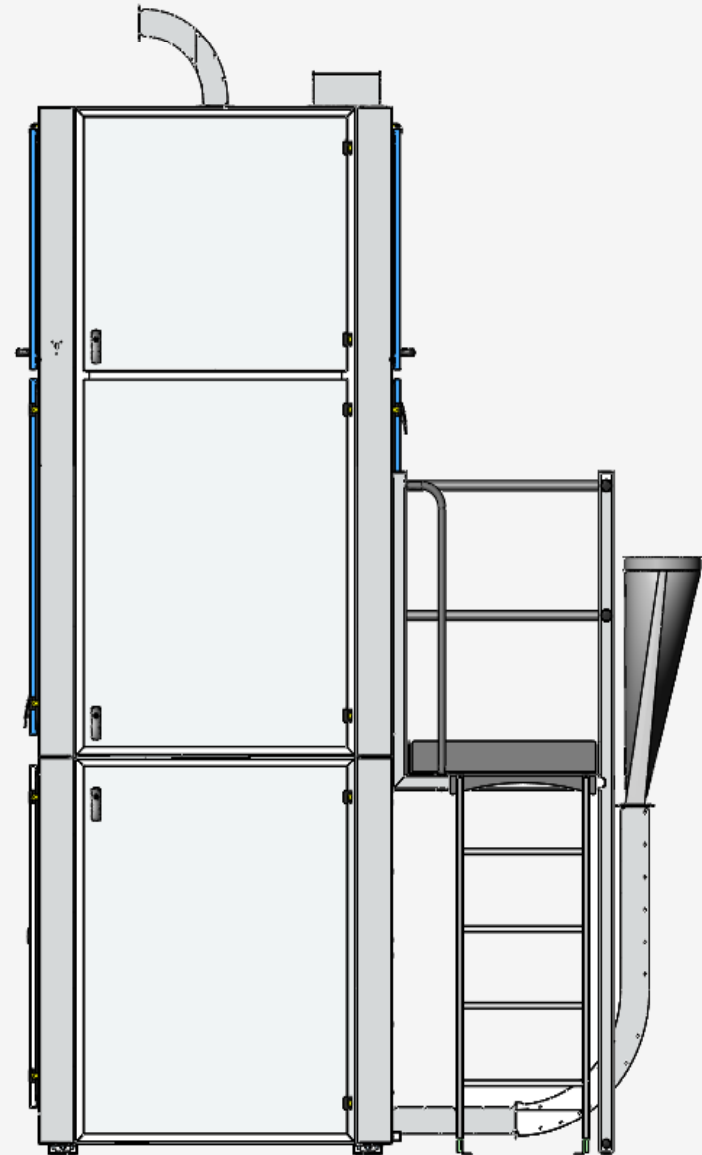

T-SCAN or TS-T 5

Electronic camera-based foreign matter separator installed in the cotton cleaning line

Scans the cotton with advanced industrial image analysis technology while tufts are passing through the machine carried by air flow

Introduced in November 2015,
delivery planned for June 2016

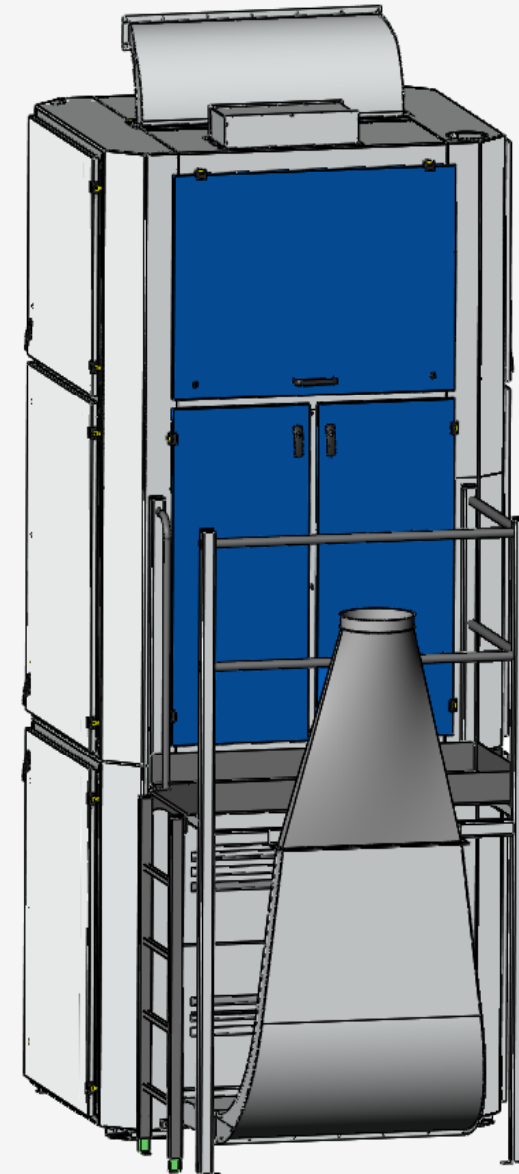

T-SCAN or TS-T 5

5 modular detection technologies

- F-Module: colored/dark/bright foreign objects
- P-Module: transparent foreign objects
- UV-Module: fluorescent foreign objects

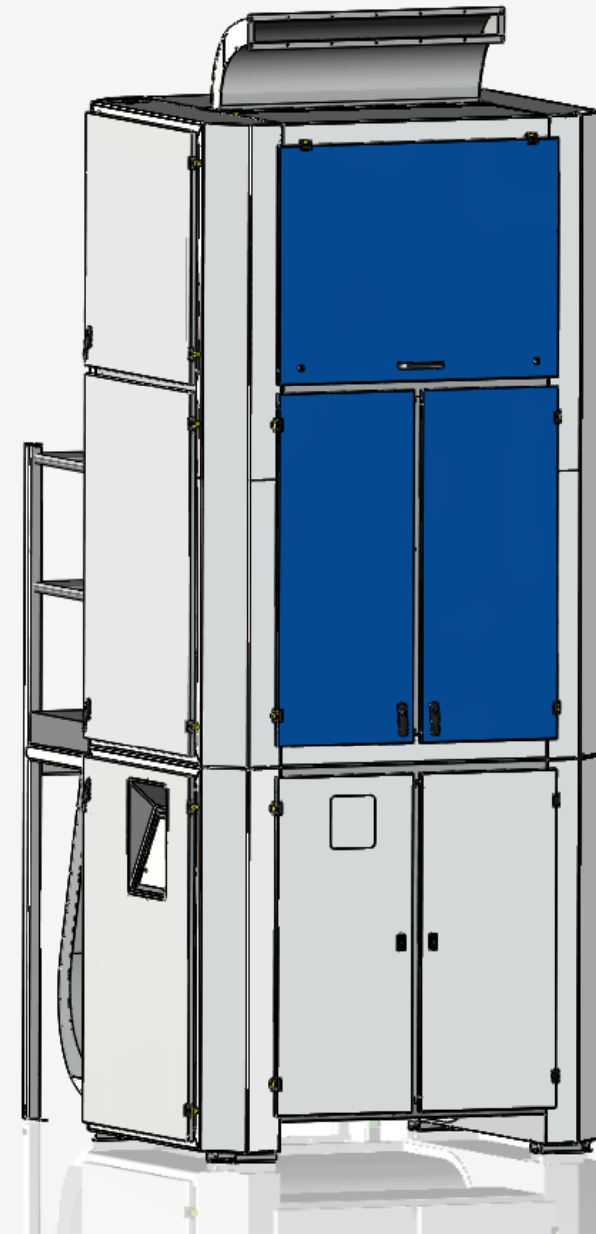

T-SCAN or TS-T 5

5 modular detection technologies

- F-Module: colored/dark/bright foreign objects
- P-Module: transparent foreign objects
- UV-Module: fluorescent foreign objects
- **G-Module: reflective foreign objects**
- **LED-Module: small/thin foreign objects**

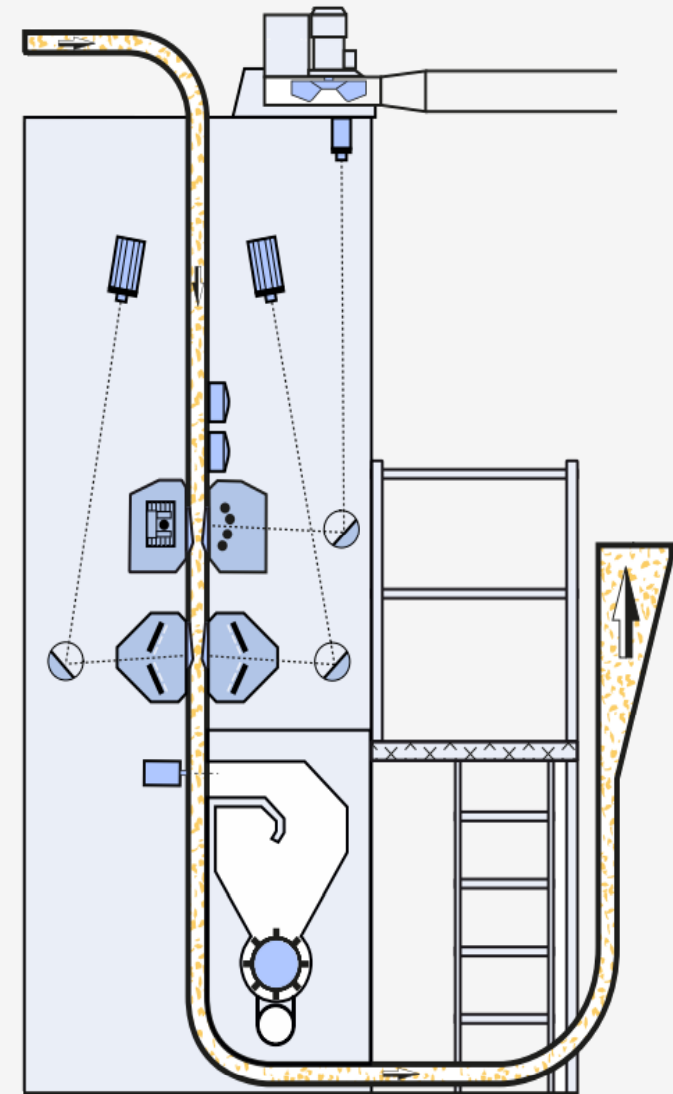

General Remarks

The biggest foreign matter problem for spinners worldwide is plastic contamination, Polypropylene (PP) in particular



Detecting PP with Standard Truetzschler Technology

F-Module: Colored PP



Visible Light,
Color/Contrast

P-Module: Transparent PP

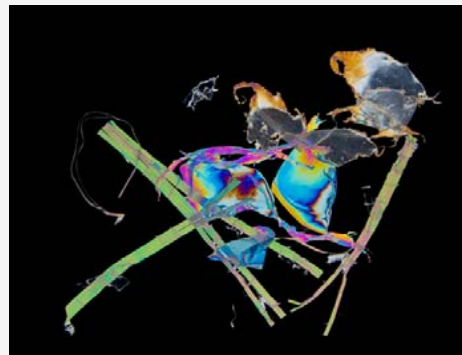

Polarized Light,
Birefringence

UV-Module: Fluorescent PP

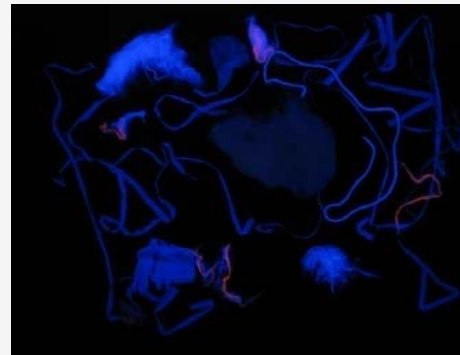

UV Light,
Fluorescence

Detecting PP with New Truetzschler Technology

G-Module: Reflective PP



Polarized Light,
Specular Reflectance

LED-Module: Small PP

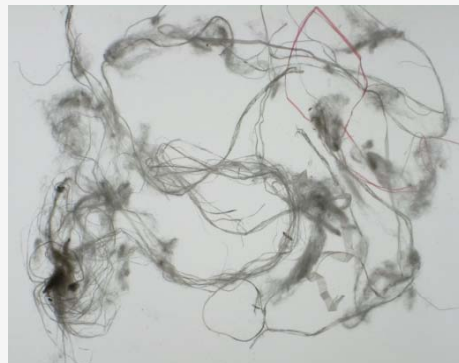

Visible Light,
Light Emitting Diodes

T-SCAN or TS-T 5: Machine Details

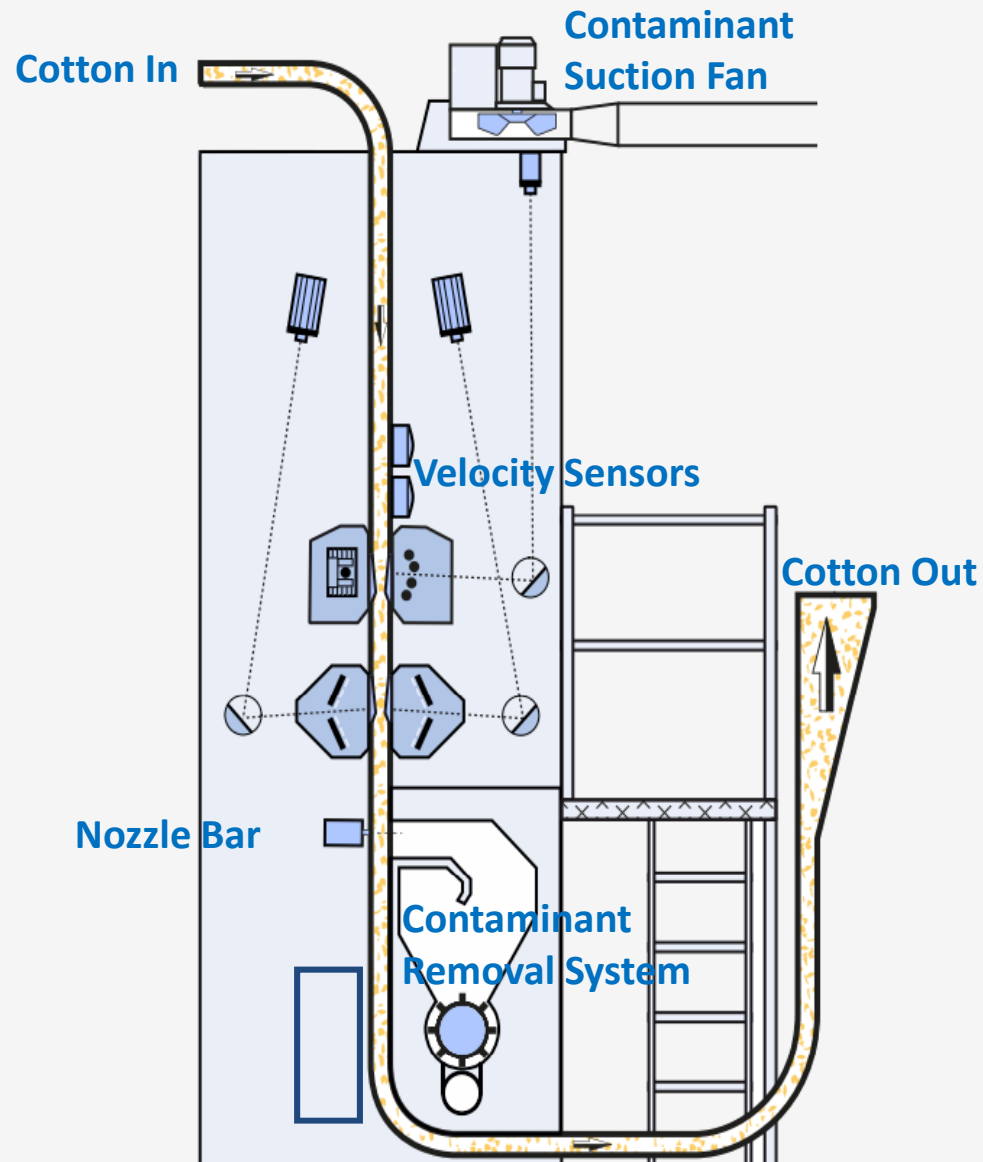

T-SCAN or TS-T 5: Machine Details

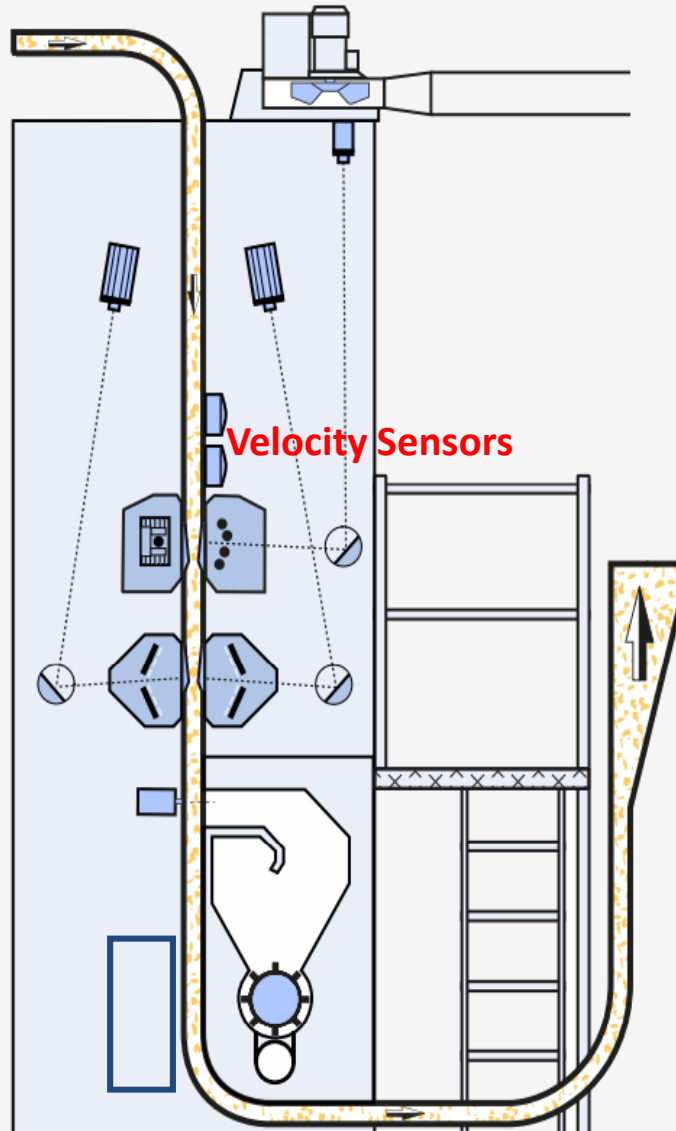

Velocity Sensors

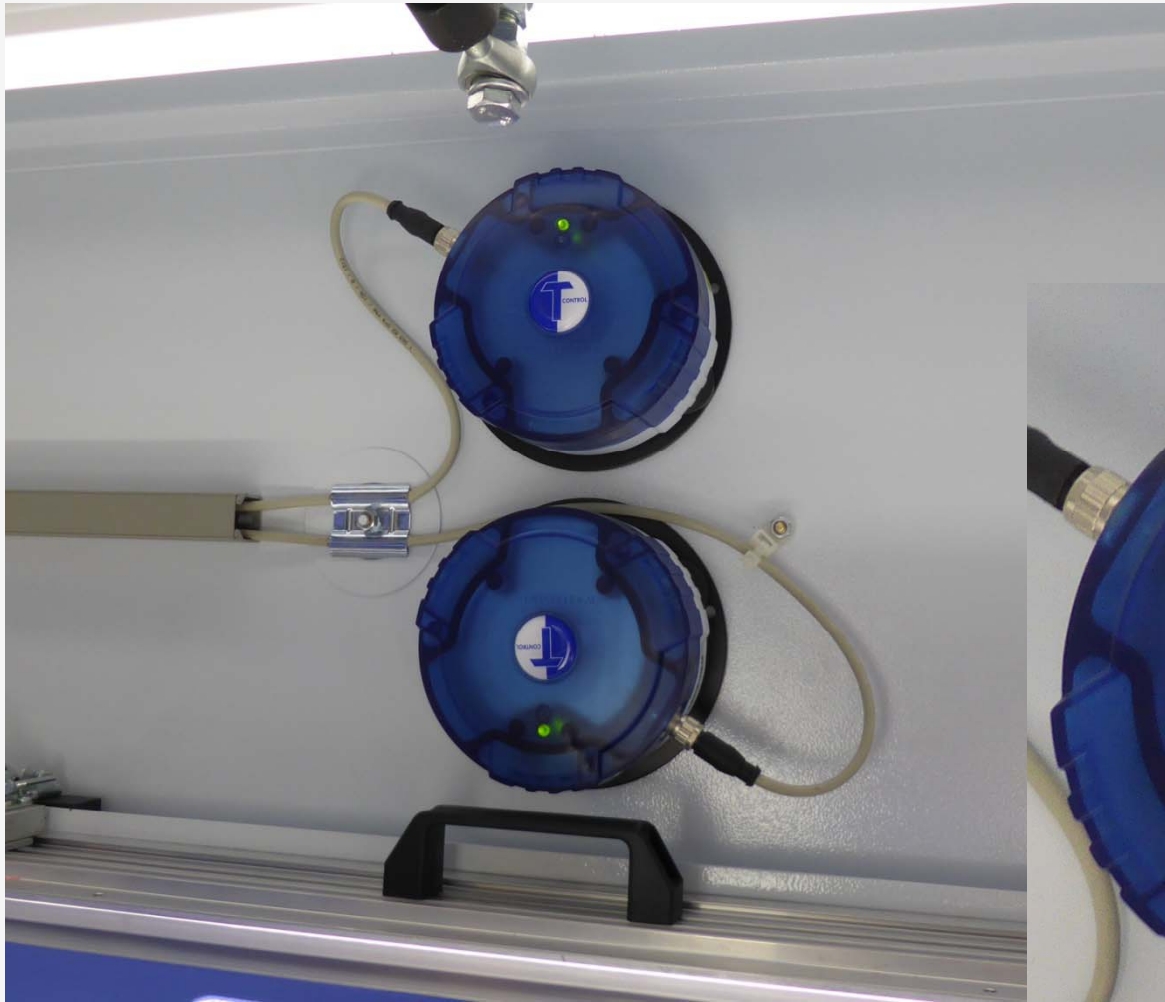

T-SCAN or TS-T 5: Machine Details

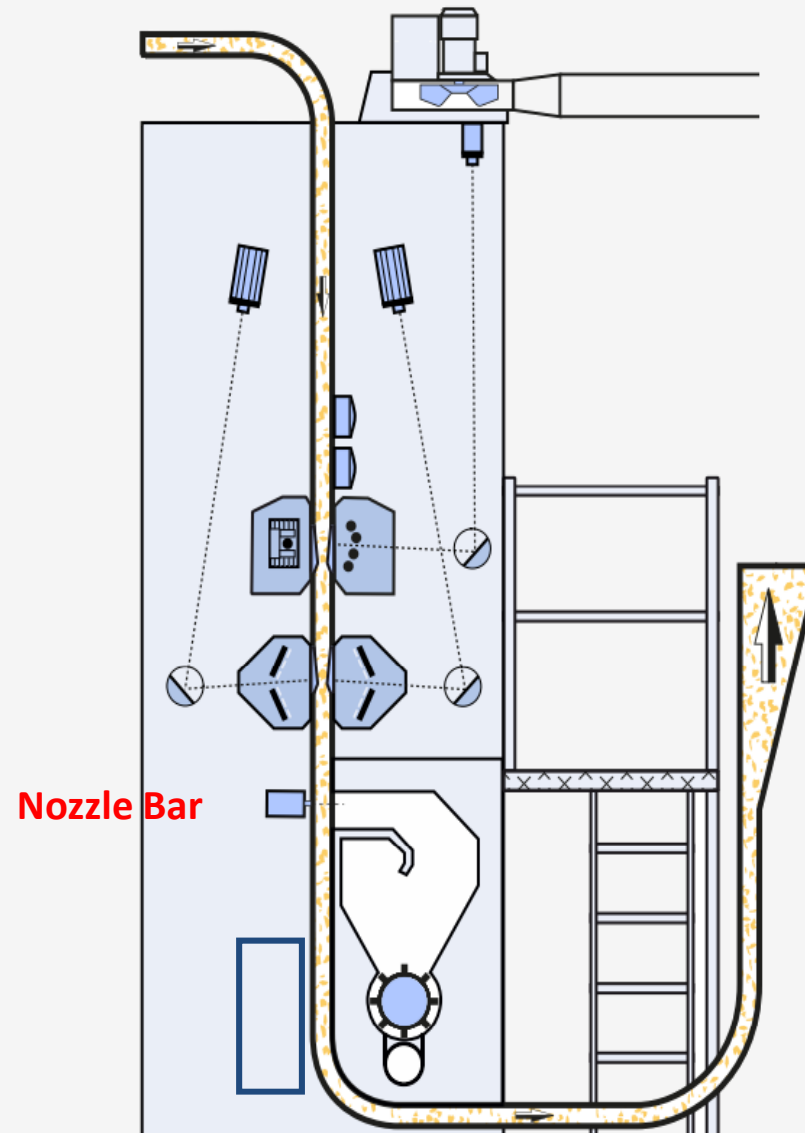

Nozzle Bar

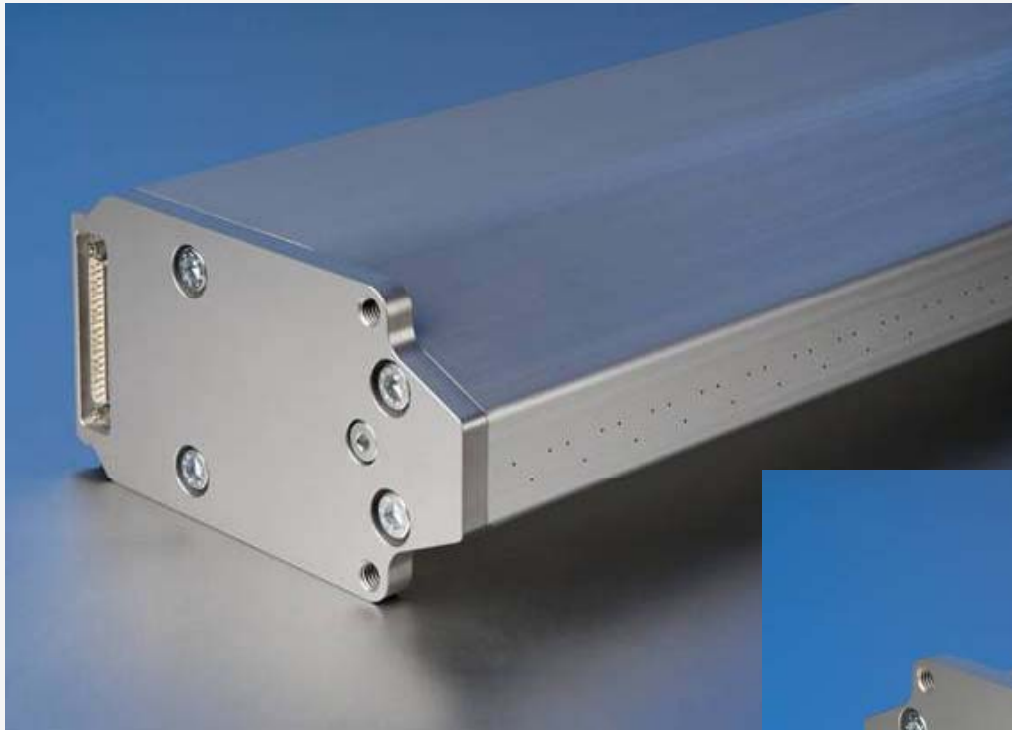

**Contaminant ejection with
144 compressed air nozzles,
individually controllable via
48 solenoid valves.
Integrated pressure tank**



T-SCAN or TS-T 5: Machine Details

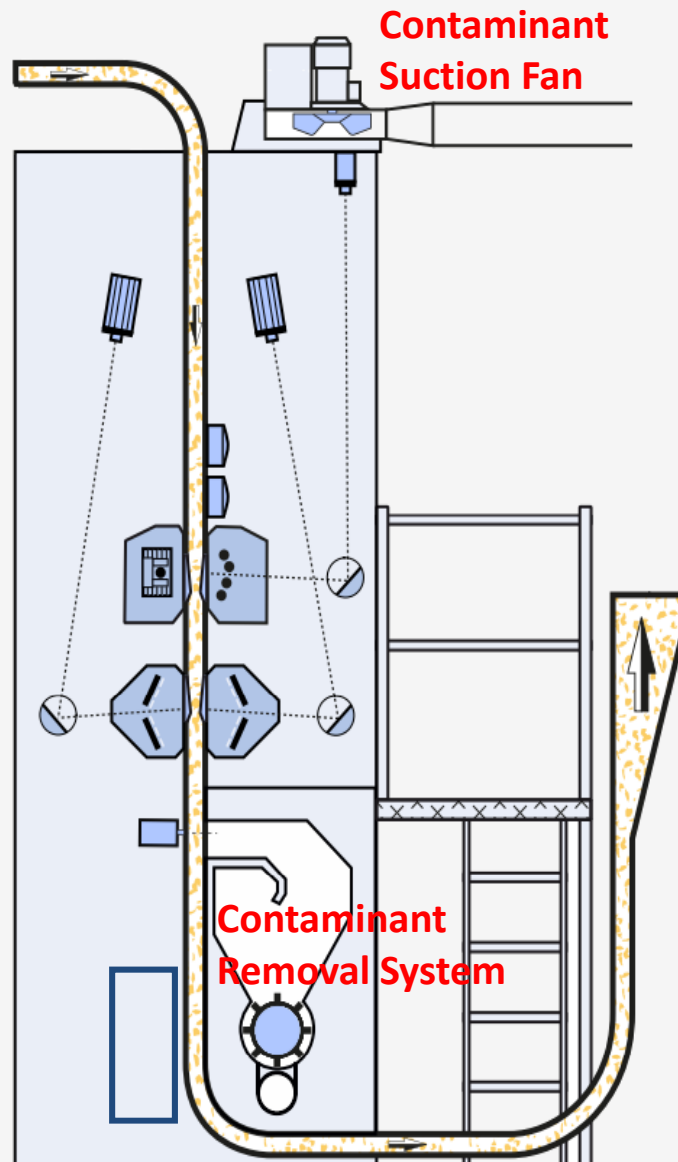

Installation Example

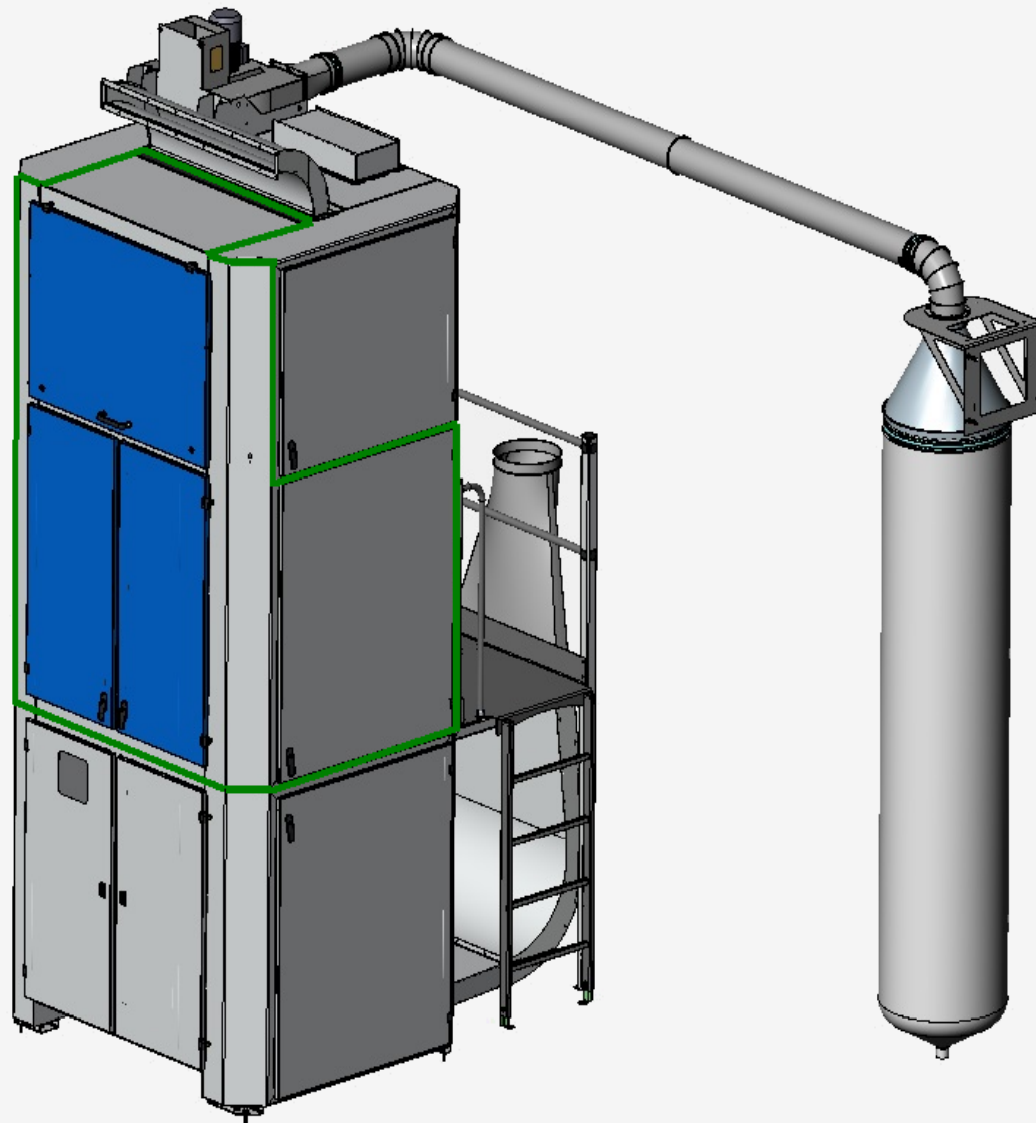

T-SCAN or TS-T 5: Machine Details

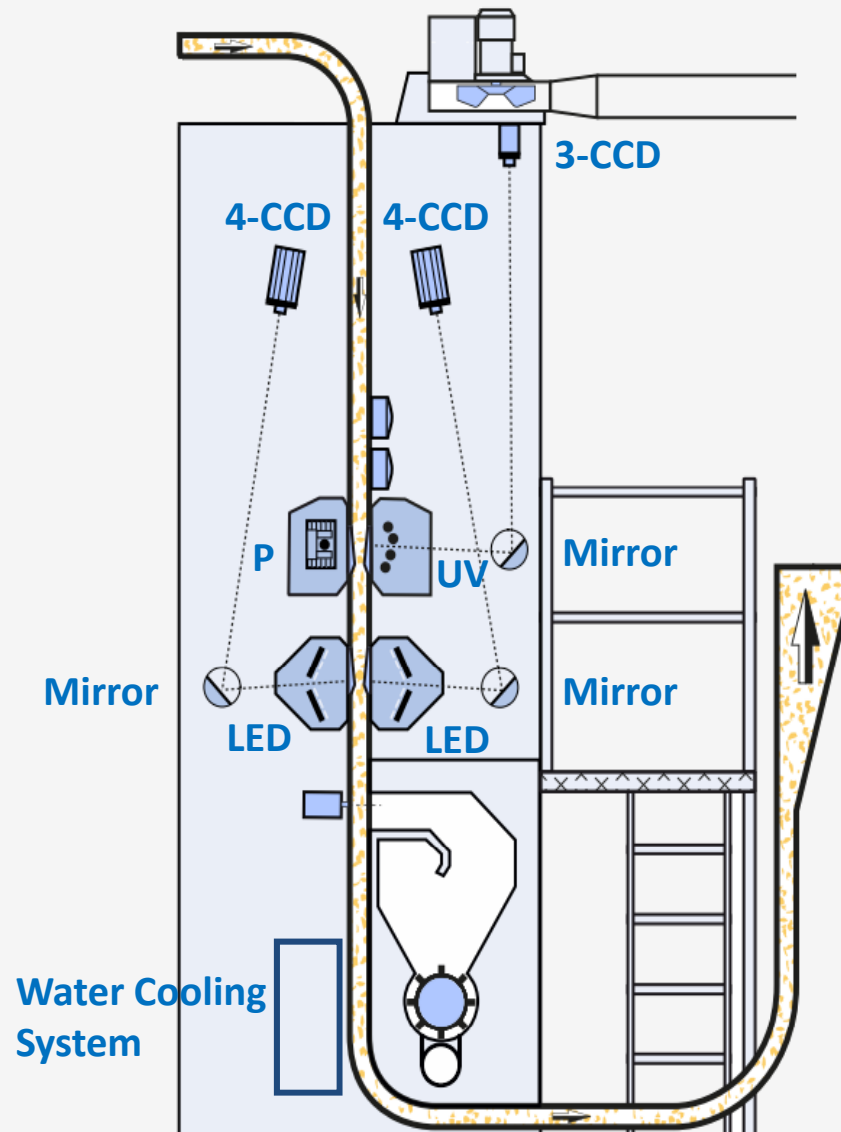

T-SCAN or TS-T 5: Machine Details

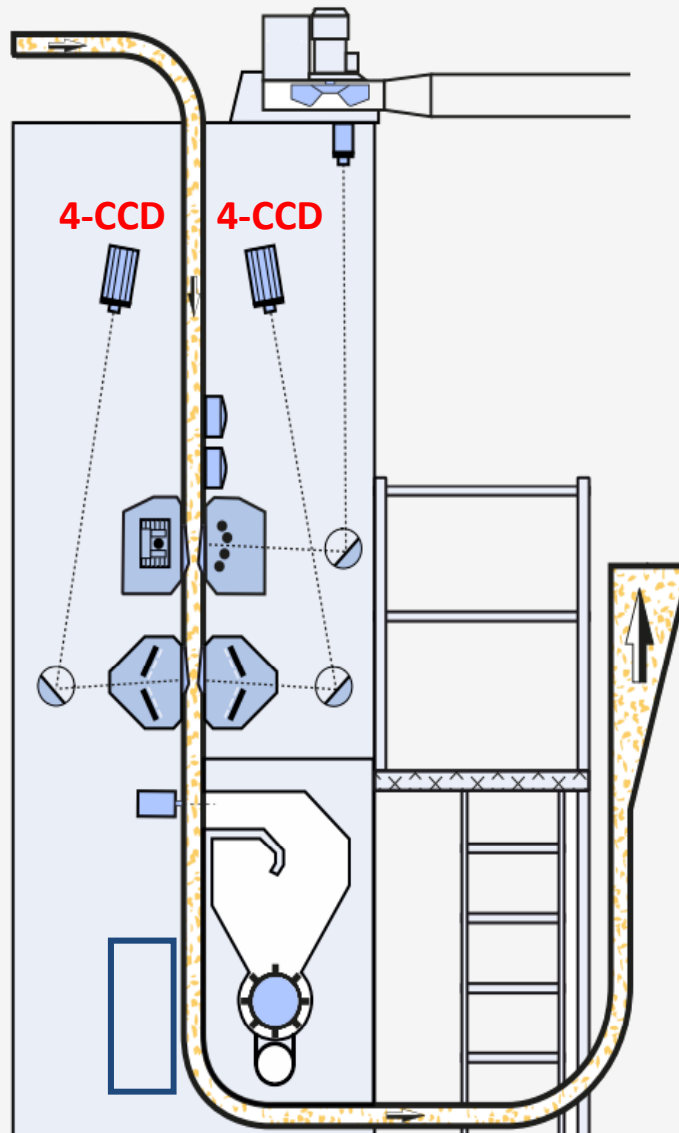

5 Detection Technologies:

F color/contrast

G reflective objects

P transparent objects

UV fluorescent object

LED small/thin objects

F and G-Module:

4-CCD cameras (T-SCAN)

LED, reflected light mode

P and UV-Module:

3-CCD camera

Fluorescent tubes, transmitted visible light mode, reflected UV light mode

LED-Module:

528 high-power LEDs and lenses

New 4-CCD Color Line Scan and Polarization Camera

- Color line scan camera for the F-Module
- Polarization camera for the G-Module
- Scanning frequency 4 x 19 kHz
- 2048 pixels/line
- Vertical resolution: 0.5 mm/line (10 m/s)
- Horizontal resolution: 0.6 mm/pixel

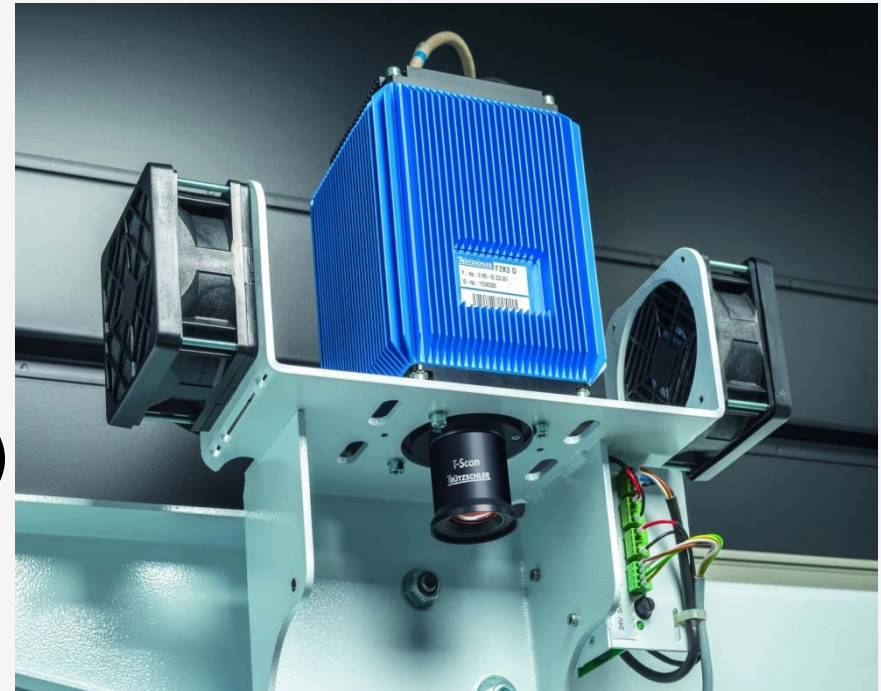

Advantages:

- Simultaneous detection of colored and reflective foreign matter such as white opaque PP or colored PP
- Detection of even the smallest pieces of foreign matter

4-CCD Line Scan Camera Technology

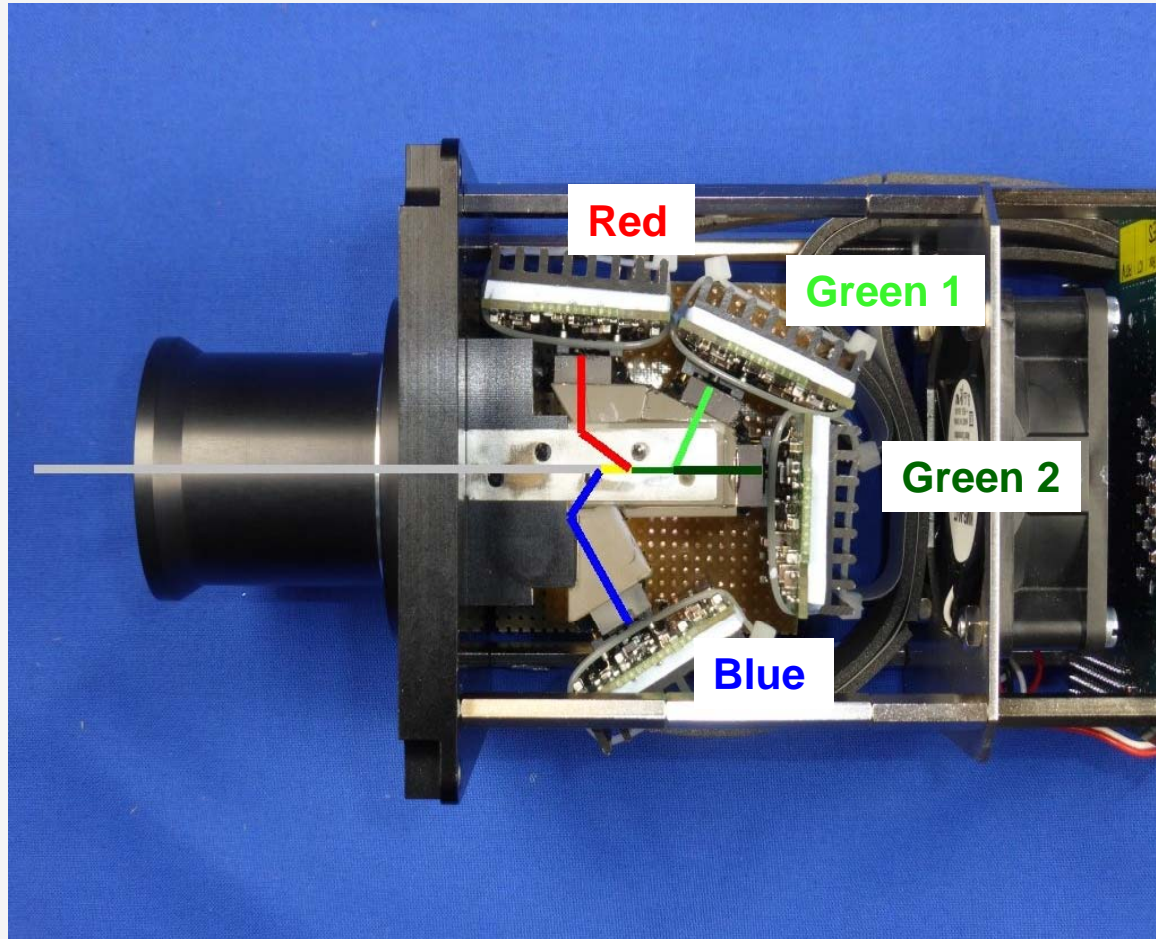

Color line scan camera:

Red, Green 2, Blue

Application in F-Module

Polarization camera:

Green 1, Green 2

Application in G-Module

Green 1: vertically polarized

Green 2: horizontally polarized

G-Module: Raw and Processed Image Data

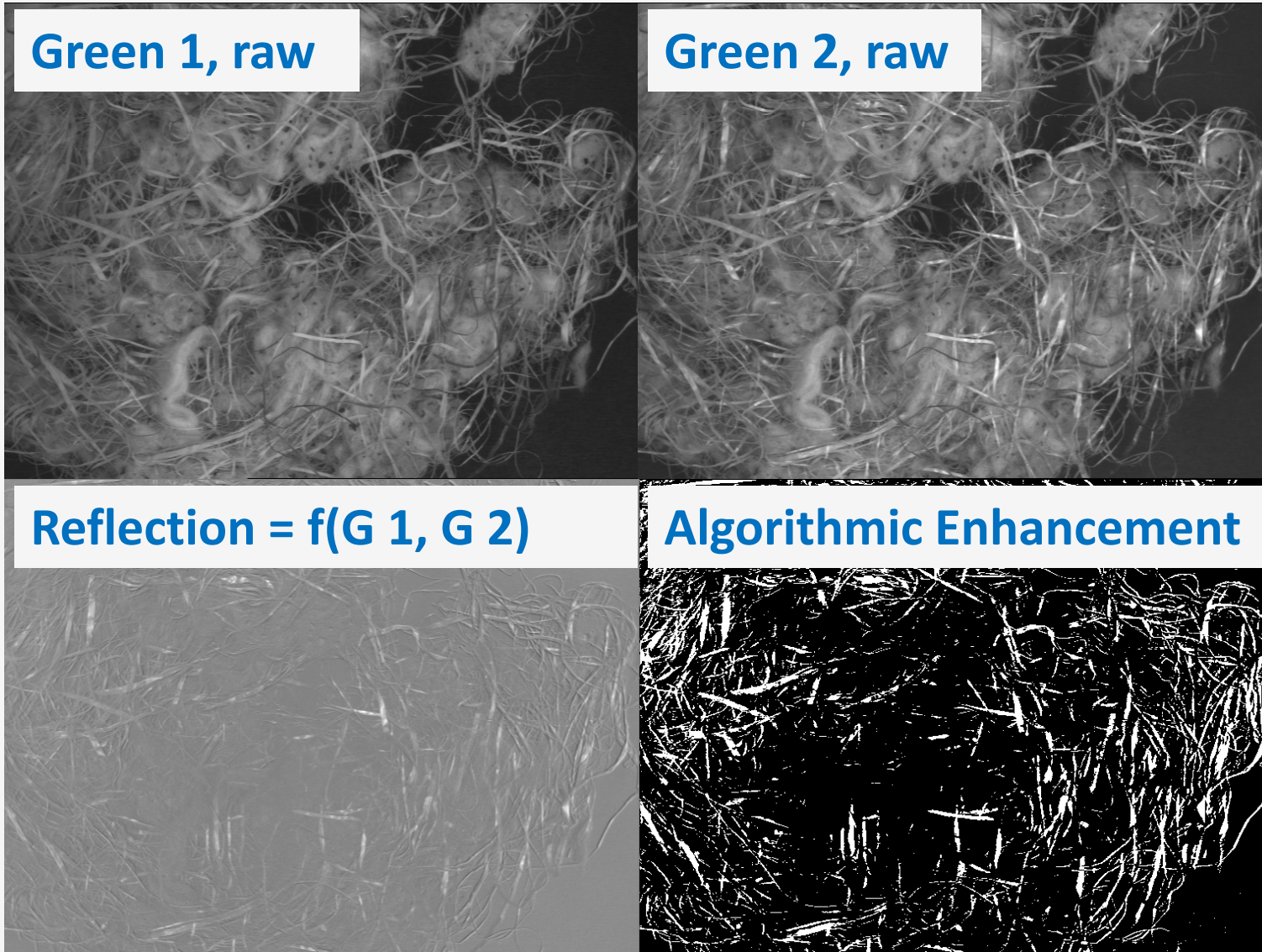

Detection Examples with Reflective Contaminants

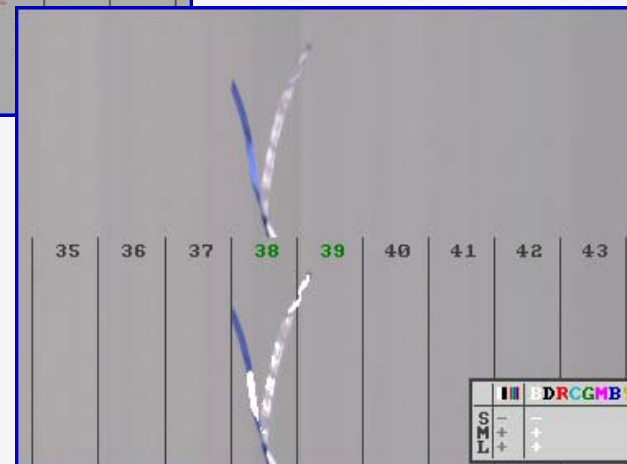
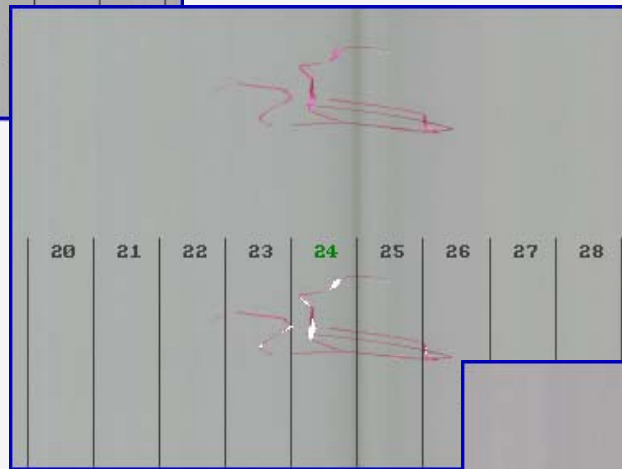
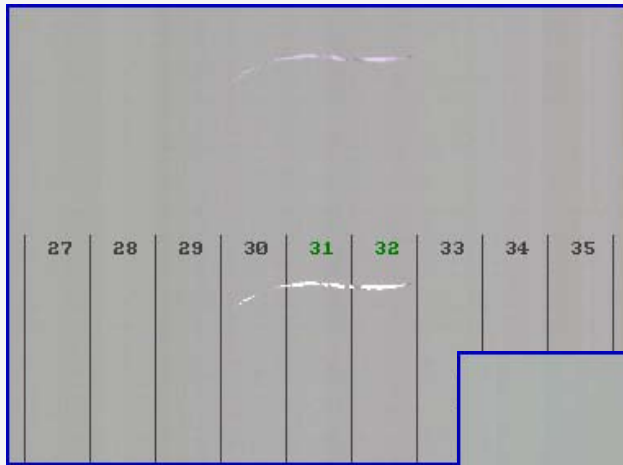

T-SCAN or TS-T 5: Machine Details

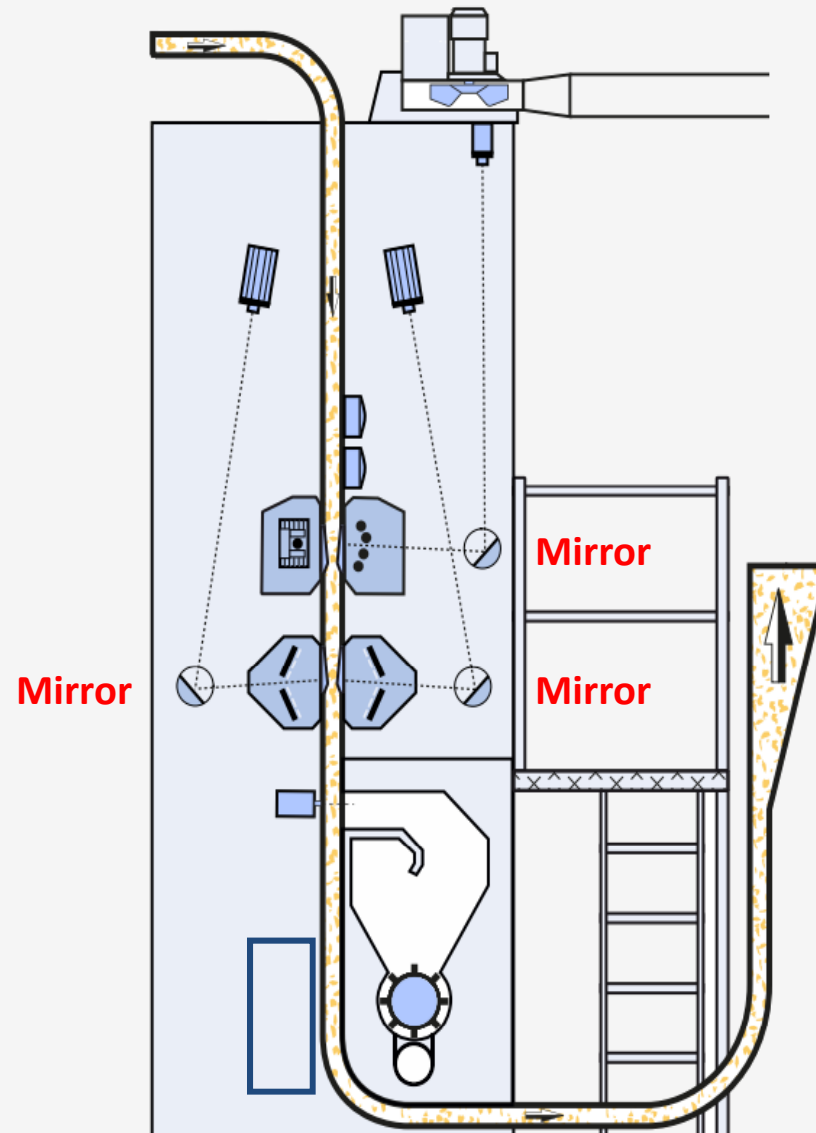

Mirrors

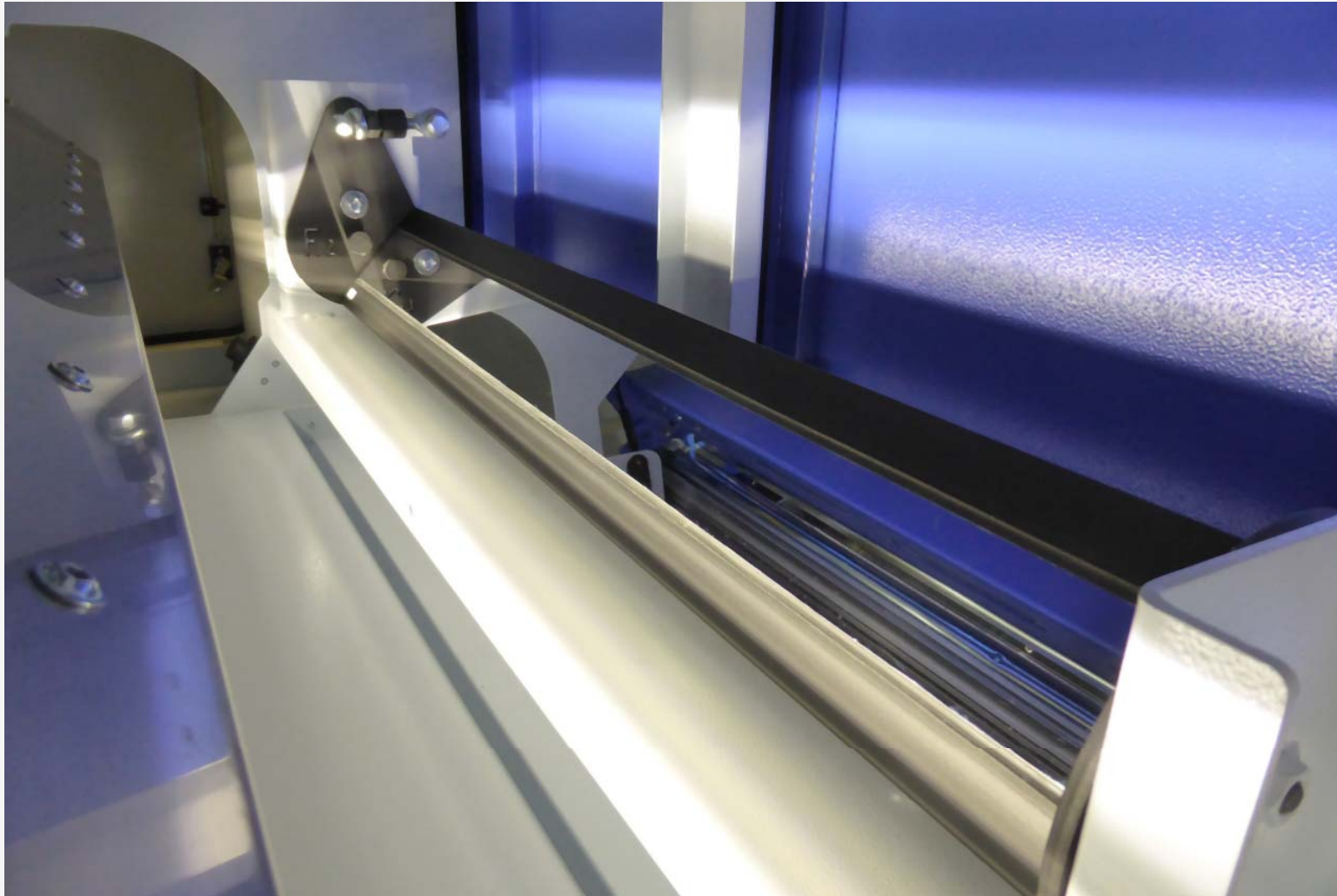

T-SCAN or TS-T 5: Machine Details

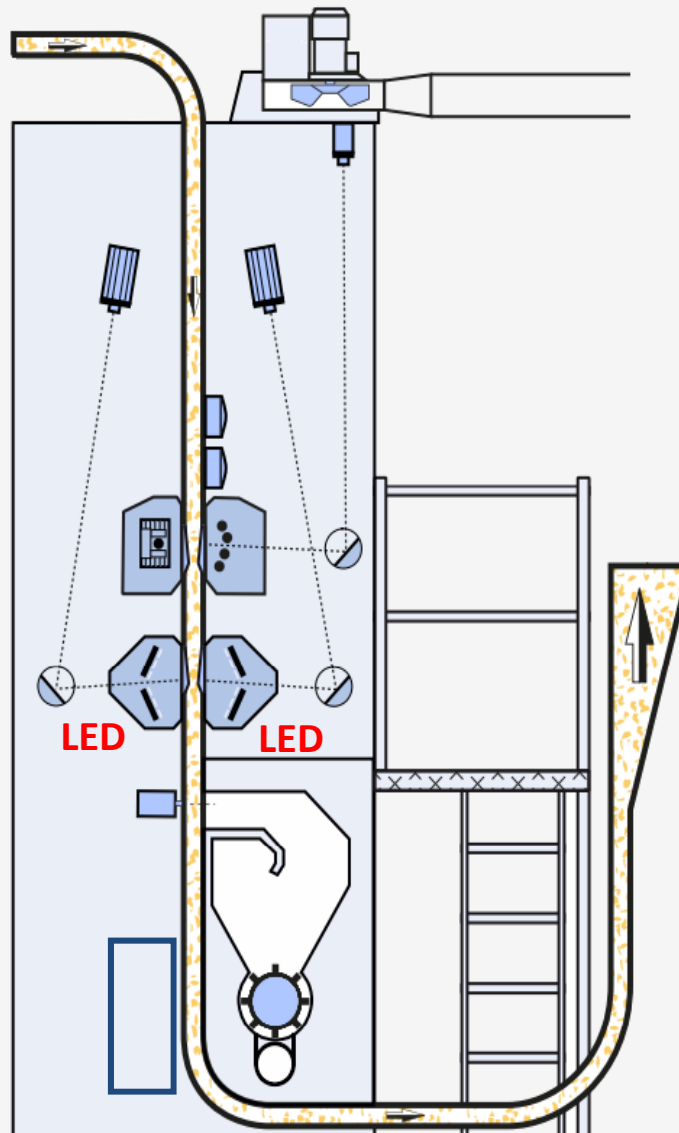

5 Detection Technologies:

- F color/contrast
- G reflective objects
- P transparent objects
- UV fluorescent object
- LED small/thin objects**

F and G-Module:

- 4-CCD cameras (T-SCAN)
- LED, reflected light mode**

P and UV-Module:

- 3-CCD camera
- Fluorescent tubes, transmitted visible light mode, reflected UV light mode

LED-Module:

- 528 high-power LEDs and lenses**

LED Illumination System

- Generates high-intensity polarized light
- Long service life due to water cooling
- Absolutely dust-proof and maintenance-free
- Light comes from 528 high-power LEDs and lenses
- Background finished in cotton color

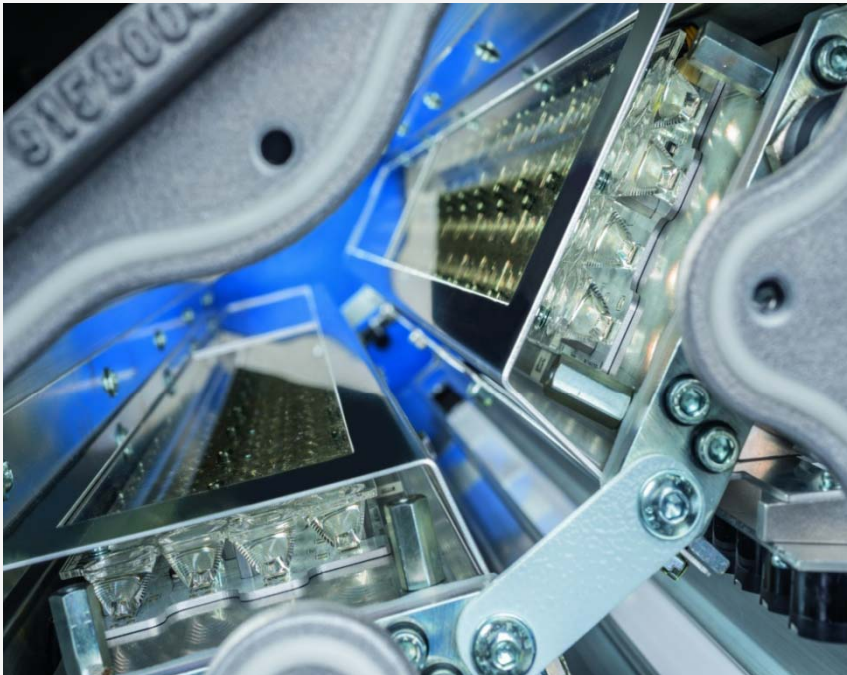

Advantages:

- very bright light
- long service life
- no maintenance

T-SCAN or TS-T 5: Machine Details

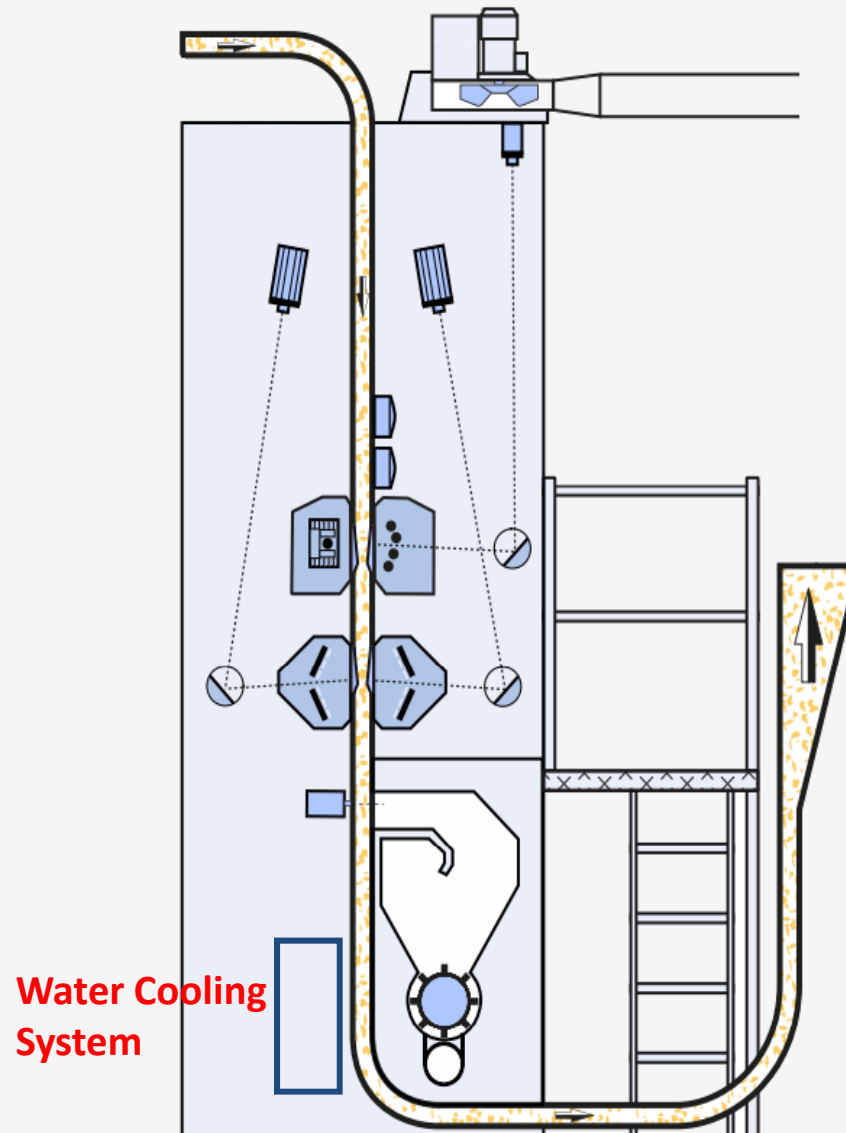

Water Cooling System

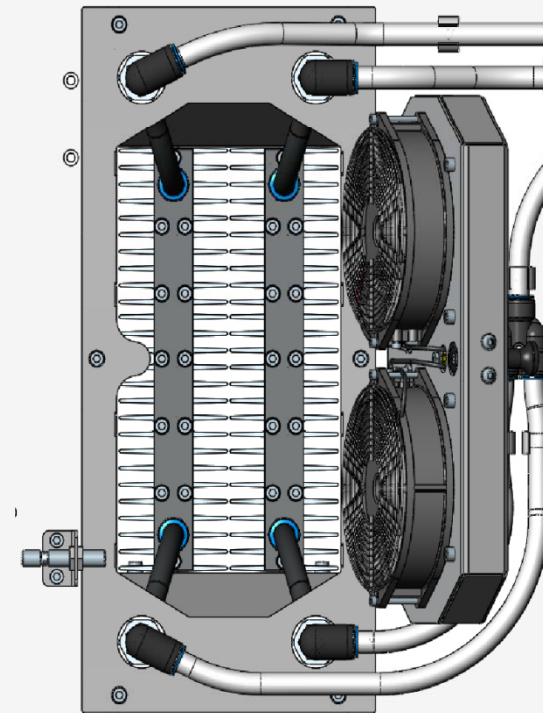
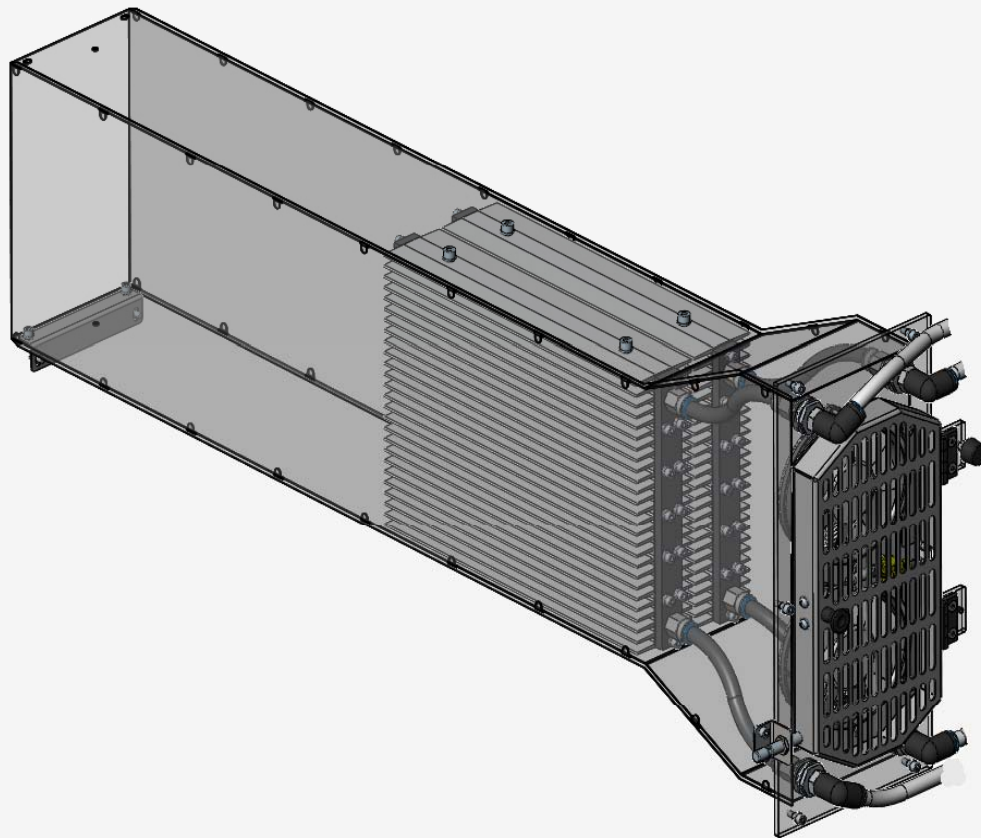

T-SCAN or TS-T 5: Machine Details

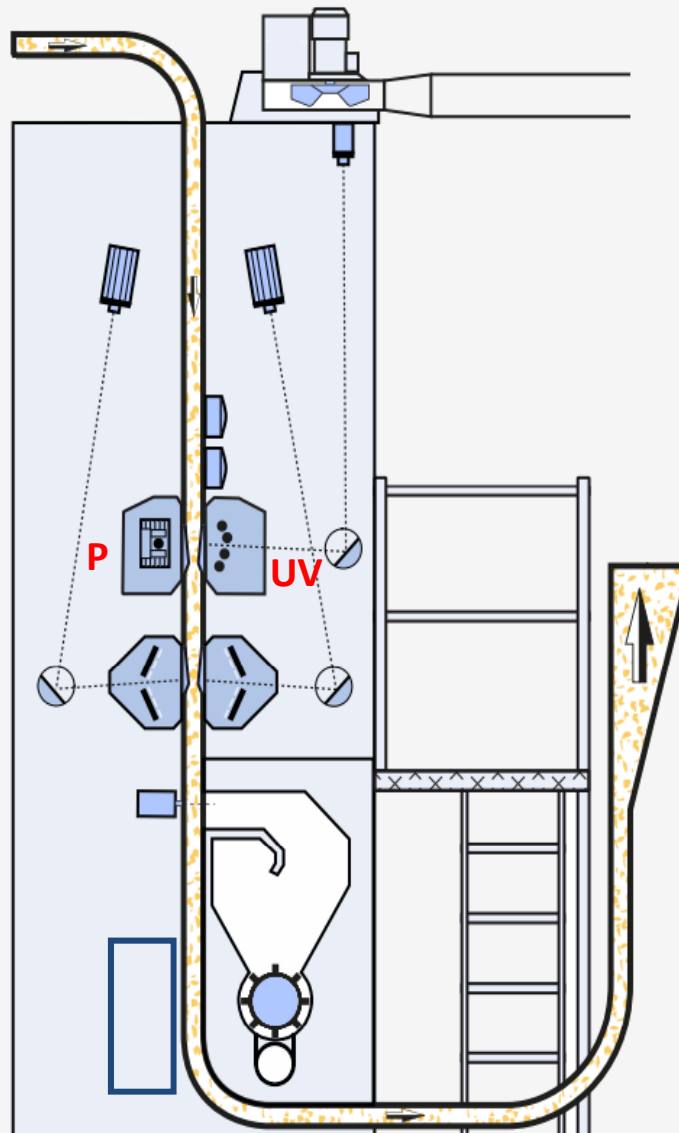

5 Detection Technologies:

- F color/contrast
- G reflective objects
- P transparent objects**
- UV fluorescent object**
- LED small/thin objects

F and G-Module:

- 4-CCD cameras (T-SCAN)
- LED, reflected light mode

P and UV-Module:

- 3-CCD camera
- Fluorescent tubes, transmitted visible light mode, reflected UV light mode**

LED-Module:

- 528 high-power LEDs and lenses

P-Module and UV-Module

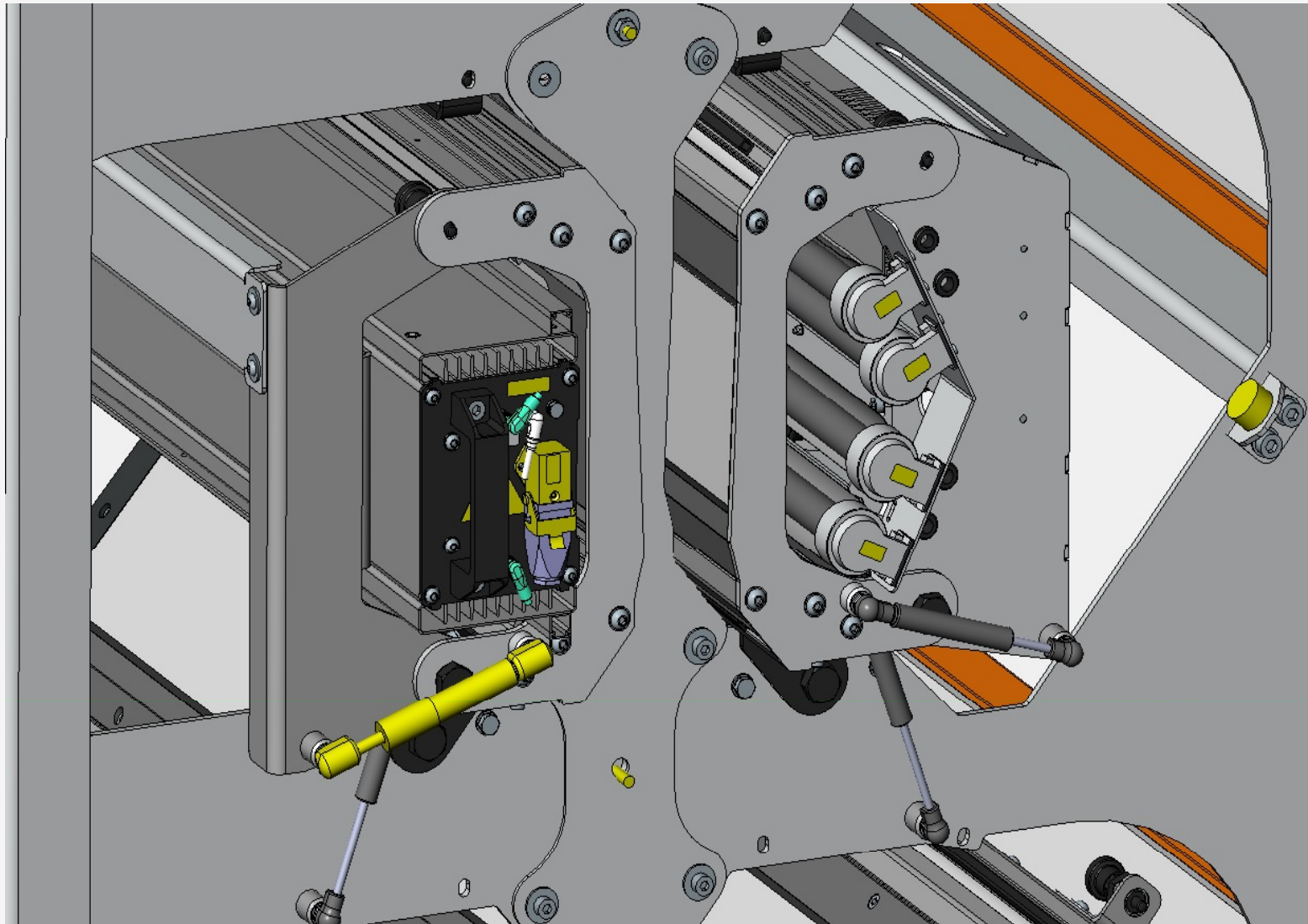

Quick and Easy Access to Illumination Systems

Operating position:
duct hermetically sealed



Service positions:
easy access to glass surfaces and fluorescent tubes



Outer Dimensions/Performance Data

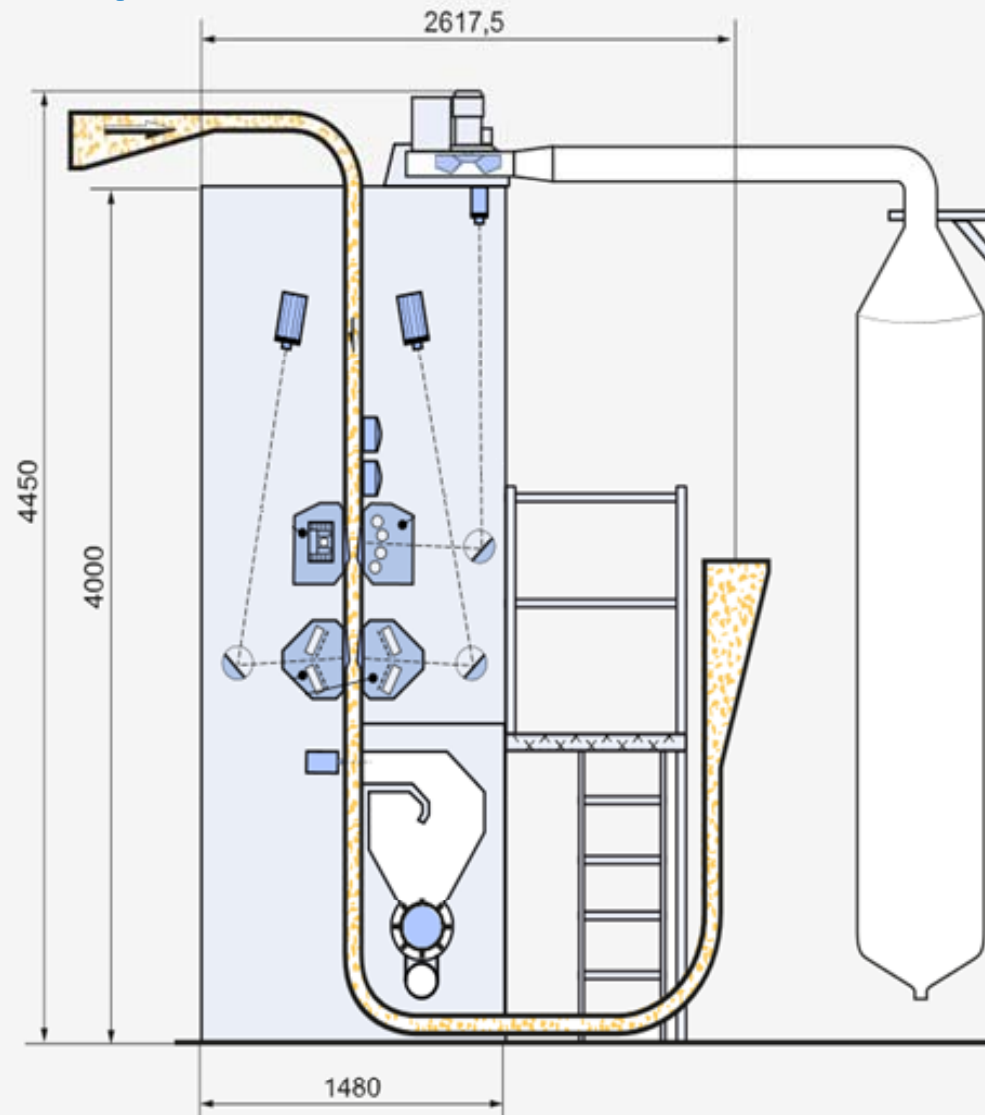

Max. production rate: **1200 kg/h**

Working width: **1200 mm**

Operation via Touch Screen Panel

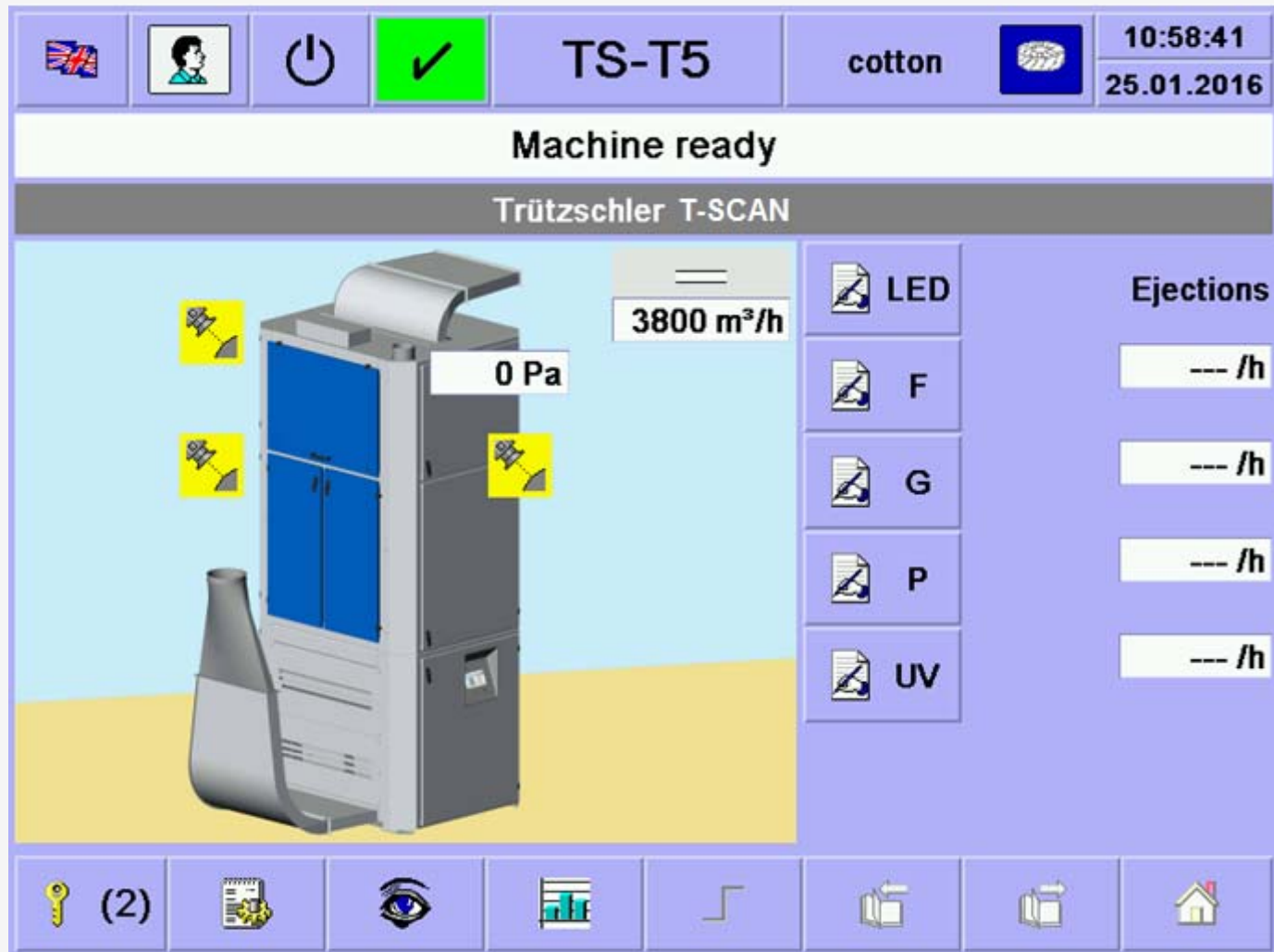

Redundancy Matrix: Simultaneous Detection with at Least Two Independent Modules

	F-Module	G-Module	P-Module	UV-Module	LED-Module
White PP	-	reflective	transparent	fluorescent	thin strips
Colored PP	colored	reflective	transparent	-	thin strips
White Plastic Film	-	reflective	transparent	fluorescent	small parts
Colored Plastic Film	colored	reflective	transparent	-	-
Threads	colored	-	-	fluorescent	thin threads
Pieces of Fabric	colored	-	-	fluorescent	-
Jute	colored	reflective	-	-	thin threads

Summary – What's New?

Summary – What's New?

- **5 modular technologies to detect all typical cotton contaminants (F, P, UV, G, and LED: color, transparency, fluorescence, reflection, and LED illumination)**

Summary – What's New?

- 5 modular technologies to detect all typical cotton contaminants (F, P, UV, G, and LED: color, transparency, fluorescence, reflection, and LED illumination)
- **Sophisticated 4-CCD color line scan and polarization camera technology for the recognition of color and reflection**

Summary – What's New?

- 5 modular technologies to detect all typical cotton contaminants (F, P, UV, G, and LED: color, transparency, fluorescence, reflection, and LED illumination)
- Sophisticated 4-CCD color line scan and polarization camera technology for the recognition of color and reflection
- **High-power, maintenance-free LED illumination technology**

Questions, Comments ... ?



TRÜTZSCHLER

Thank you very much for
your time



S P I N N I N G

You can also visit us on the
internet

www.truetzschler.com